

Product

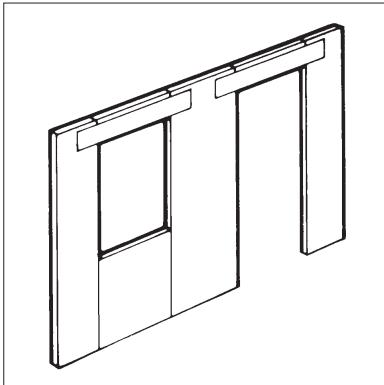

• THIS DETAIL SHEET RELATES TO THE PANABLOK 100 PREFORMED STRUCTURAL WALLING SYSTEM, COMPRISING CEMENT PARTICLE BOARD INTERNAL AND EXTERNAL FACES WITH A POLYURETHANE FOAM CORE.

• The walling panels are for use above the damp-proof course to construct the loadbearing or non-loadbearing leaf of internal or external cavity, or single leaf walls in conjunction with an internal plasterboard liner.

This Detail Sheet must be read in conjunction with the Front Sheets, which give the product's position regarding the Building Regulations, and the Conditions of Certification.

Technical Specification

1 Description

1.1 The Panablok 100 Preformed Structural Walling System comprises an inner and outer skin of cement particle board with an injected core of closed cell, polyurethane foam, free of CFC blowing agent. Cold formed metal studs are incorporated within the foam and between the cement particle board skins at nominal 600 mm centres.

1.2 The panels have the nominal dimensions of:

thickness (mm)	86
width (mm)	600, 1200
height (mm)	2400, 2475, 2700
weight (kg)	80, 82, 88 (respectively)
edge detail	plain lapped (corner panels only)

1.3 Panels are also available to order with additional insulation and plasterboard components added to the inner face to improve the thermal properties.

1.4 The skins of the walling panels consist of 8 mm thick, cement particle board class 1 to BS EN 634-2 : 1997.

1.5 The core of the walling panels is 70 mm thick and consists of a polyurethane foam with a minimum density of 35 kgm⁻³.

1.6 Head and base channels are manufactured from 1.2 mm thick steel. The metal studs within the panels are manufactured from 0.7 mm thick steel and the lintel angle from 2.4 mm thick steel. These components are manufactured from steel to

BS EN 10326 : 2004 with a hot-dip galvanized grade of S220 GD + Z275 N-A-U.

1.7 Each walling panel contains three camlocks on each vertical edge. The camlock casings are manufactured from high-impact styrene, the hooks from 3 mm thick mild steel with a zinc die-cast cam and mild-steel-plated, hook-locating rivet (see Figure 1).

Figure 1 Camlock detail

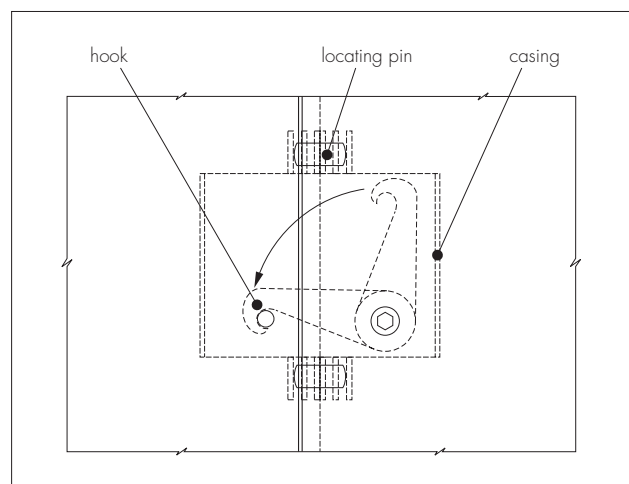

1.8 Ancillary components for the walling panels include:

- timber battens
- wall tie — proprietary type of stainless steel grade 304
- plasterboard — to BS 1230-1 : 1985 or with a current BBA Certificate
- timber frame wall ties — with a current BBA Certificate
- fixings — selected from a range of self-tapping screws supplied by the Certificate holder

- various fixing angles and brackets
- joist hangers — manufactured from 1.2 mm thick steel to BS EN 10326 : 2004 galvanized to grade S220 GD + Z275-N-A-U (used primarily in conjunction with 2700 mm high panels).

2 Delivery and site handling

2.1 All panels are delivered to site in packs, the number of panels in each pack may vary depending upon the size of the panels.

2.2 Each panel carries the manufacturer's name and the BBA identification mark incorporating the number of this Certificate.

2.3 Care must be taken in unloading, stacking and storing the panels to prevent damage. On site, panels should be stored clear of the ground and covered until use to prevent water accumulation.

2.4 The panels should be lifted from the stack and not dragged across it.

Design Data

3 General

3.1 The Panablok 100 Preformed Structural Walling System is suitable for the construction of loadbearing walls in buildings up to 10 metres, or three storeys high. The overall building design should take into consideration and accommodate differential movement.

3.2 When the product is used to construct the inner leaf of an external cavity wall, the outer masonry leaf and all masonry below the dpc must be designed and constructed in accordance with BS 5628-1 : 1992 and BS 5628-3 : 2001.

3.3 When the product is used as a single-leaf external wall the joints must be sealed with a suitable silicone sealant and can be painted with the suppliers' recommended Pliolite resin-based paint. The single-leaf construction should only be used in sheltered/moderate exposure conditions, as defined in BS 5628-3 : 2001.

3.4 When the product is used as part of a cavity wall construction it is acceptable to NHBC and Zurich Building Guarantee Technical Standards for use in domestic dwellings only.

3.5 All structural design and detailing involving the use of the product must be carried out by or under the direct supervision of chartered structural or civil engineers or appropriately qualified persons, in accordance with UK practice, conditions and Building Regulations.

4 Structural performance

4.1 The characteristic design values to be used when evaluating the design resistance of the product are given in Table 1.

Table 1 Design load values (kNm^{-1})

Design load resistance ⁽¹⁾	Panel height (mm)		
	2400	2475	2700
Characteristic vertical load	60.0	57.7	55.0
Characteristic horizontal load	1.5	1.4	1.2
Basic racking	2.6	2.5	2.2

(1) Loads calculated generally in accordance with BS 5268-2 : 2002, using load factor of 1.6 and material partial factor of 1.5.

4.2 The characteristic vertical load resistance given in Table 1 is based on the load being applied axially to the panels (eg floor loading, timber joists placed directly above the walling panels). Where metal joist hangers are used (see Figure 2) and nailed to the timber joists (using the correct number of nails supplied), the hangers must be screwed to the walling panel in accordance with the Certificate holder's instructions. The allowable eccentric load for this type of construction is given in Table 2.

Figure 2 Loading arrangement using joist hangers

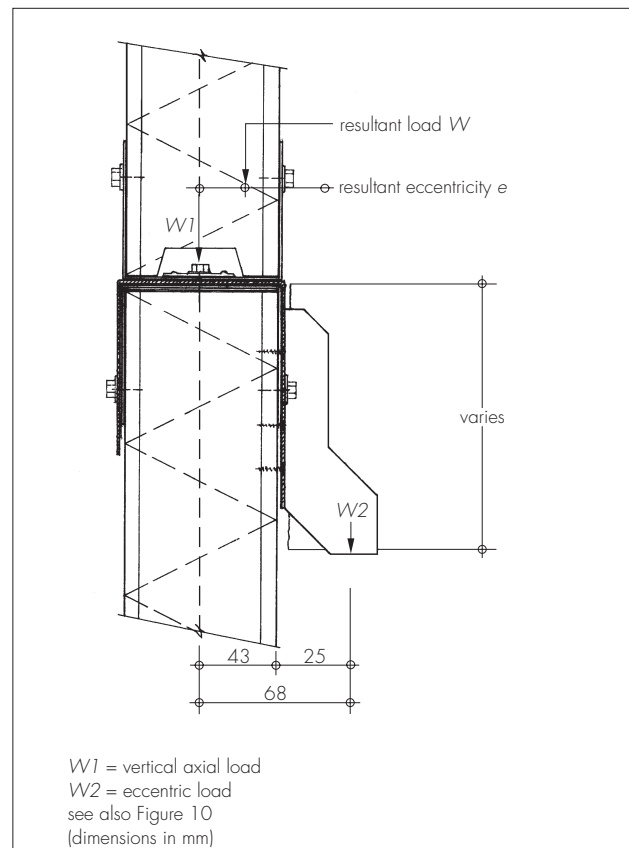

Table 2 Characteristic eccentric vertical load — 2700 mm panels

Axial load (kNm^{-1})	Proportion of max axial load (%)	Eccentric load (kNm^{-1}) ⁽¹⁾
55	100	0.0
44	80	0.3
33	60	4.0
22	40	7.8
11	20	11.6
0	0	15.4

(1) Based on maximum eccentricity of 25 mm from face of panel.

4.3 The strength of all connection details which tie walls, comprising the product, to other structural elements (such as walls, floors, roofs, columns) must be evaluated and provide adequate stability for the overall building design. The specification and design for these items must be determined by the engineer responsible for the stability of the building. Guidance on the design of connection details may be obtained from the Certificate holder.

4.4 The product has adequate resistance to the hard and soft body impacts likely to occur in practice and is satisfactory for use in locations described in categories C to F of BS 8200 : 1985.

4.5 Lintels to be used with the Panablok 100 Preformed Structural Walling System are supplied by the Certificate holder and are designed in accordance with BS 5950-5 : 1998 (see Figure 3 and Table 3). For cavity wall construction, BBA approved lintels can be used with a minimum bearing of 300 mm (see the relevant Certificate for installation details).

Figure 3 Typical Panablok 100 lintel

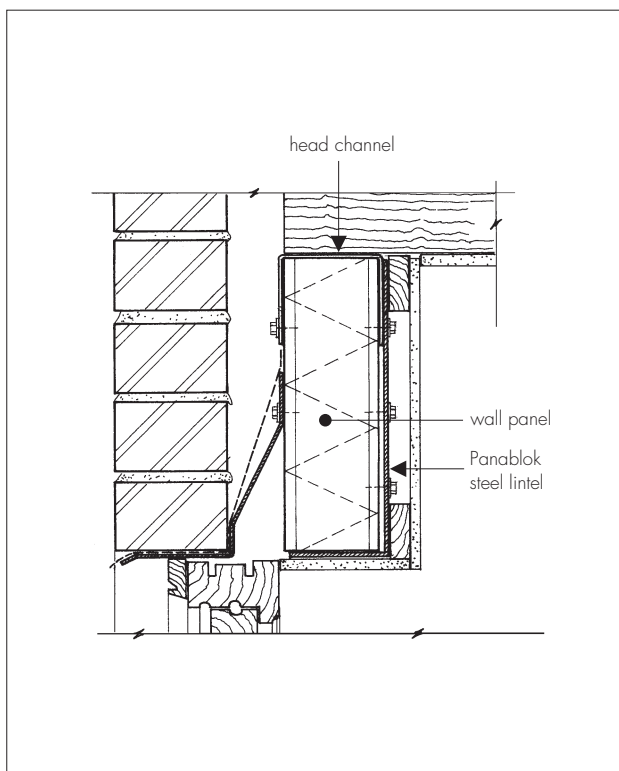

Table 3 Load/span for single-leaf L-shape lintels

Effective span ⁽¹⁾ (mm)	Clear opening (mm)	Load (kNm ⁻¹)
1500	1200	15.9
2100	1800	8.1
2700	2400	4.9
3300	3000	3.3

(1) Total length of lintel = Effective span (distance between centre of bearings) + 300 mm.

5 Condensation risk



5.1 When used in a typical construction, detailed in section 6.1, the risk of damage due to interstitial or surface condensation in normal domestic conditions is minimal. For other constructions, a vapour control layer should be specified unless calculations to BS 5250 : 2002 show that it is not necessary.

5.2 It is essential that joints between the walling panels are properly made to prevent the passage of water vapour into the wall construction. When plasterboard is used with a service space behind, penetrations of the plasterboard (ie electrical services) should be kept to a minimum.

6 Thermal properties



6.1 The U value of a wall comprising a Panablok 100 panel lined with 12.5 mm plasterboard on timber battens and 50 mm cavity with brick outer leaf, when calculated to BS EN ISO 10211-1 : 1996 and BS EN ISO 10211-2 : 2001 is 0.34 Wm⁻²K⁻¹.

6.2 A wall constructed with the product and achieving the appropriate U value, will meet or satisfy the requirements of the Elemental Method of compliance with the national Building Regulations:

England and Wales

Approved Documents L1 and L2, Table 1

Scotland

Technical Standards, Table 1 to J3.2 and Table to J8.3

Northern Ireland

Technical Booklet F, Tables 1.2 and 1.4.

6.3 The wall panels can adequately limit heat loss and surface condensation risk at junctions and around openings when detailed in accordance with the relevant design guidance given in *Limiting thermal bridging and air leakage : Robust construction details for dwellings and similar buildings* TSO 2002.

7 Sound insulation



7.1 When tested to BS EN ISO 140-4 : 1998 the separating wall construction detailed in Figure 4, flanked with Panablok external cavity wall, an insulated ground floor with 75 mm screed, 13 mm plasterboard on 69 mm timber stud and quilt internal partitions and timber trussed rafter roof over timber/plasterboard ceiling with 200 rock wool insulation, provided satisfactory resistance to airborne sound transmission. See Tables 4 to 6, section 7.3 and 14.6 of this Detail Sheet.

Figure 4 Plan view separating wall detail — sound insulation

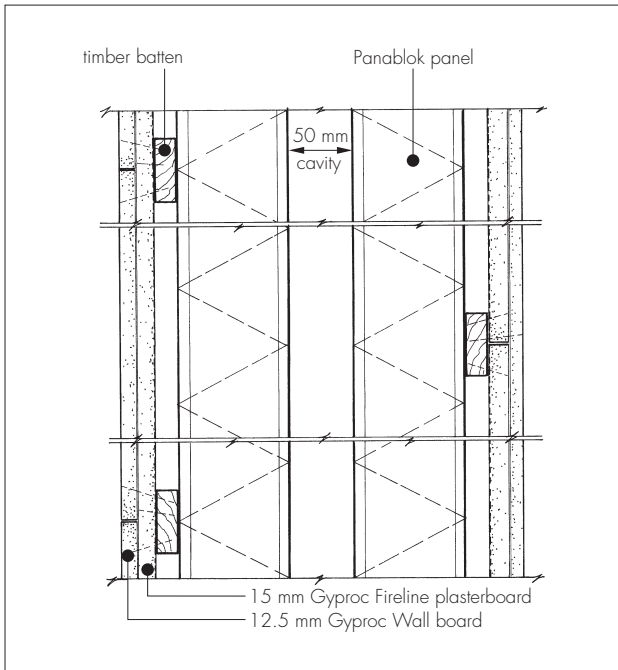

Table 4 Sound insulation (dB) — Field test results

Room pairs tested ⁽¹⁾	Airborne $D_{nT,w}(C_f, C_w)$
Lounge plot 2 to lounge plot 1	57 (-5; -10)
Lounge plot 7 to lounge plot 6	60 (-5; -10)
Bedroom plot 7 to bedroom plot 8	63 (-3; -10)
Lounge plot 10 to lounge plot 9	57 (-5; -11)

(1) See Building Test Centre report BTC 10840A

Table 5 Sound insulation (dB). Deemed to satisfy — England and Wales

Purpose built dwelling-houses and flats	Airborne $D_{nT,w} + C_{tr}$
	≥45

Table 6 Sound insulation (dB). Deemed to satisfy — Scotland and Northern Ireland

	Airborne $D_{nT,w} + C_{tr}$
Scotland and Northern Ireland (new constructions)	
Mean value for:	
Up to four pairs of rooms	≥52
Individual value	≥48



7.2 Separating walls incorporating the product in England and Wales are subject to pre-completion testing in accordance with Section 1 of Approved Document E.



7.3 The measures to be taken in design and during installation to avoid direct paths for airborne sound transmission are given in section 14.6 of this Certificate and the national Building Regulations:

England and Wales

Approved Document E

Scotland

Technical Standards, Part H of the provisions deemed to satisfy the standards

Northern Ireland

Technical Booklet G.

7.4 Test data for other construction details are available from the Certificate holder but are outside the scope of this Certificate.

8 Behaviour in relation to fire



8.1 Assessment of test results of fire resistance to BS 476-21 : 1987, show that:

- walling panels for separating walls protected internally by 12.5 mm thick Gyproc Wall board and 15 mm thick Gyproc Fireline boards (see Figure 4) and subject to the characteristic axial load given in Table 2 will achieve a 60-minute fire resistance from either side⁽¹⁾
- 2700 mm walling panels for external walls protected by one sheet of 12.5 mm thick Gyproc Wall Board (see Figure 5) and subject to an eccentric load of 25 kNm⁻¹ at a resultant eccentricity of 28 mm will achieve a 30-minute fire resistance from the inside⁽²⁾
- 3050 mm by 2400 high wall panel and one layer of 15 mm Lafarge Firecheck board on 25 mm thick timber battens with the addition of 15 mm polyurethane foam layer in the formed cavity subject to an applied load of 60 kN⁻¹m⁻¹ achieved a 30 minute fire resistance.⁽²⁾

(1) Medium duration in Scotland.

(2) Short duration in Scotland.

Figure 5 External wall finish — 30 minute fire protection

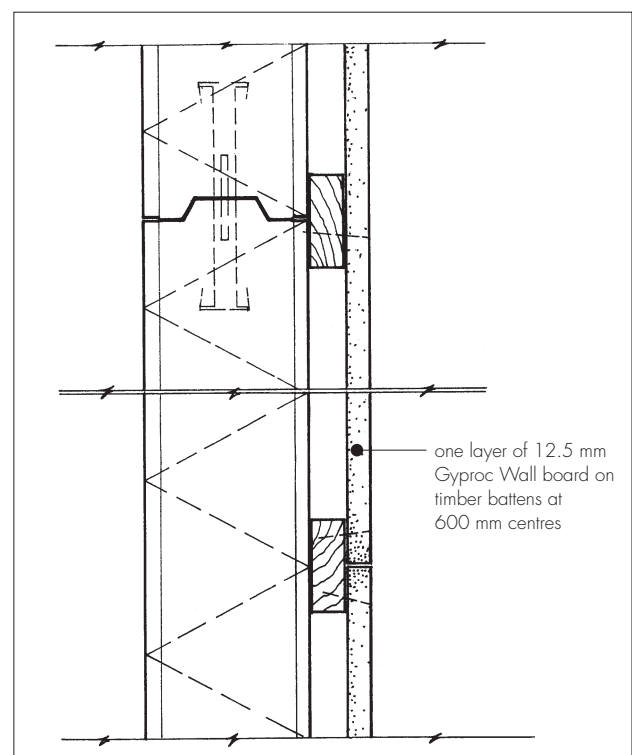

8.2 The panel linings have the following surface spread of flame designation:

- plasterboard Class 0 (before decoration)⁽¹⁾
- cement-bonded particle board Class 0⁽¹⁾.

(1) 'Low risk' in Scotland.

8.3 Test data for other construction details are available from the Certificate holder but are outside the scope of this Certificate.

8.4 Where any other form of wall construction incorporating the product is subject to fire resistance requirements, or if an internal plasterboard not covered by a separate BBA assessment is used, an appropriate assessment or test must be carried out by a UKAS (United Kingdom Accreditation Service) approved testing laboratory.

9 Practicability of installation

The product is practicable for use in constructing walls in buildings. All site erection must be carried out in accordance with the Certificate holder's installation instructions and this Detail Sheet.

10 Weathertightness

10.1 When the Panablok 100 Preformed Structural Walling System is used to form the inner leaf of an external masonry wall the outer leaf must be designed and constructed in accordance with BS 5628-1 : 1992 and BS 5628-3 : 2001 incorporating dpc's and cavity trays positioned in accordance with the latter code. A breather membrane is not necessary in conjunction with this product.

10.2 The product can be used in the construction of single external walls [in conjunction with sealant (see section 3.3)], in sheltered/moderate exposure conditions as defined in BS 5628-3 : 2001, Table 10, and depicted as exposure zones 1 and 2 in the map contained in section 3.1 of BRE Report BR 262 : (2002 edition) *Thermal insulation : avoiding risks*. The dpc's should be positioned in accordance with the same British Standard and all panel joints must be sealed using a suitable silicone sealant in accordance with BS 6093 : 1993.

11 Moisture content

In common with all timber-based products, cement bonded particle board is subject to moisture movements. It is good practice that all timber products should have a moisture content at the time of installation close to that which they will experience in service. The panels should be factory conditioned to achieve a moisture content close to that experienced in service. Guidance is given in BS EN 634-2 : 1997.

12 Maintenance

To ensure adequate durability of single-leaf construction, regular maintenance inspections

followed by appropriate remedial action should be carried out on the weather protective systems. The required frequency of routine repainting will be similar to that normally associated with external woodwork, the interval not exceeding 8 to 10 years. Repainting should be carried out in accordance with BS 6150 : 1991 and the sealants replaced in accordance with BS 6093 : 1993.

13 Durability



The product will have a durability comparable to that of Portland cement-bonded particle board as defined in BS EN 634-2 : 1997. Therefore, providing all aspects outlined in sections regarding *Weathertightness* and *Moisture content* are adhered to, a lifetime of at least 60 years may be expected.

Installation

14 General

14.1 The installation of the Panablok 100 Preformed Structural Walling System must comply with the Certificate holder's installation instructions. Installation should be carried out by an approved contractor who has completed the Certificate holder's training programme.

14.2 The main contractor should provide a minimum of two setting-out grid lines at right angles to each other.

14.3 Bearings must be type SR2 in accordance with BS 8204-1 : 2003. The overall plan dimensions are checked for squareness and size against the construction drawings before installation commences. The high point of the bearing must be identified and used as a datum to which all base channels on the bearing will be set.

14.4 Base channels may be raised above the bearing by packing to level. Any void under the channel must be filled with a loadbearing material as work proceeds (eg mortar).

14.5 Where any galvanized steel base, head or corner channel or lintel is cut on site, the cut face must be re-treated with a zinc-rich paint.

14.6 It is essential that the design and installation is strictly in accordance with good building practice and the requirements of this Certificate, to ensure that paths for sound transmission through the separating wall assembly and the flanking elements are minimised. The following items should be checked for each installation:

- the wall is as shown in Figure 4
- the Panablok panels are not connected to each other
- plasterboard joints are filled, taped and staggered between layers

- junctions between the flanking and abutting elements and the separating wall are suitably sealed.

15 Procedure

15.1 Base channels must be fixed to the bearing using the appropriate self-tapping anchor fixings at 400 mm centres installed working away from the first corner.

15.2 The first section of the walling panel is erected working from the corner for stability and head channels located onto the walling as work proceeds away from this point.

15.3 The corner panels are joined together vertically using site-formed lapped joints as shown in Figure 6. Top and base channels lock the corner panels into position with self-drilling screws being provided at 200 mm centres. A pressed steel corner angle is screw fixed to the external face to provide additional protection.

Figure 6 Lapped corner joint

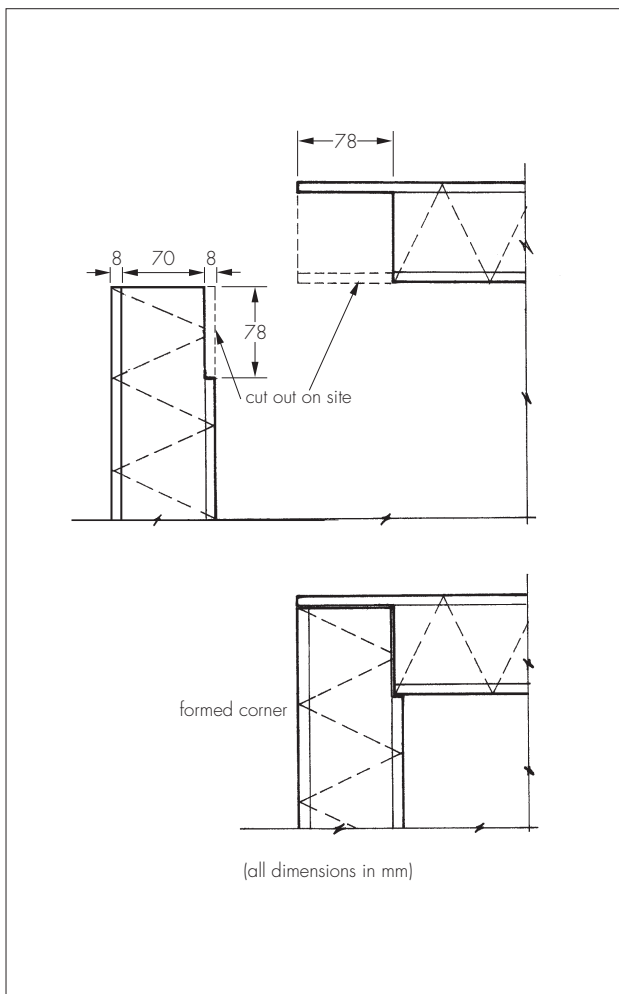

15.4 The next walling panel in the sequence is erected and the joint is secured using the camlocks within the panel (see Figure 1). The walling must be supported at a maximum of 3600 mm nominal centres, ie every third walling panel (see Figure 7). This process is repeated accordingly.

Figure 7 Propping arrangement

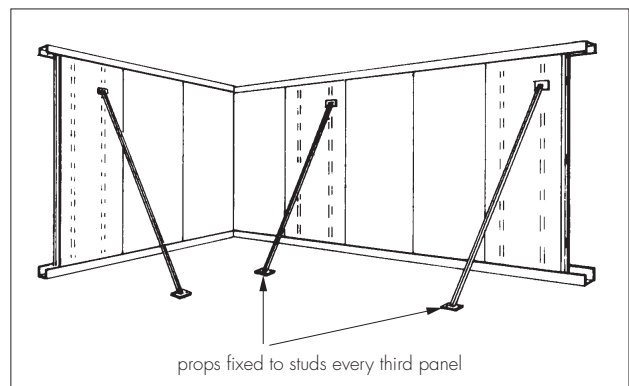

15.5 Walls are checked for line and level and props adjusted as necessary (see Figure 7).

15.6 The walling panels are secured to the base, head, corner channels and lintels sections using self-drilling fasteners provided, at 200 mm centres and the pre-drilled holes in the channel and lintel sections.

15.7 Where internal intersecting walling panels are required a vertical channel is fixed to the internal face of existing external or cross-walls and secured with screws at 200 mm centres through the vertical channel pre-drilled holes. The installation is then completed as for external walls.

15.8 On external walls, the joint between the external upstand of any galvanized channel and the walling panel must be sealed with the sealant provided.

15.9 Other storeys are constructed using the previous procedures. Intermediate floor connections are detailed in the Certificate holder's installation instructions and shown in Figures 3 and 8 and can be adapted according to the walling panel height and detail required.

Figure 8 Typical intermediate floor connections

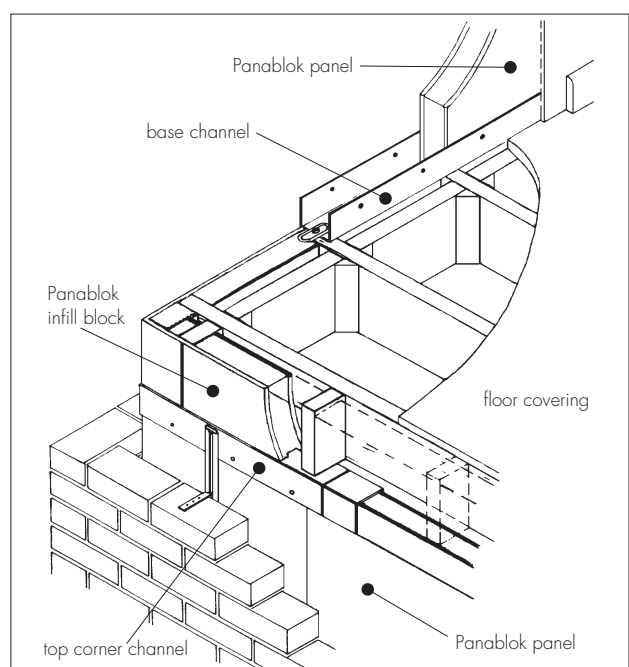

15.10 The legs of joist hangers must be bent over the top and down the back face of the panel. The hanger and the leg are fixed by screws (see Figure 9). Details of suitable hangers and screws (including number and location) can be obtained from the Certificate holder.

Figure 9 Joist hanger

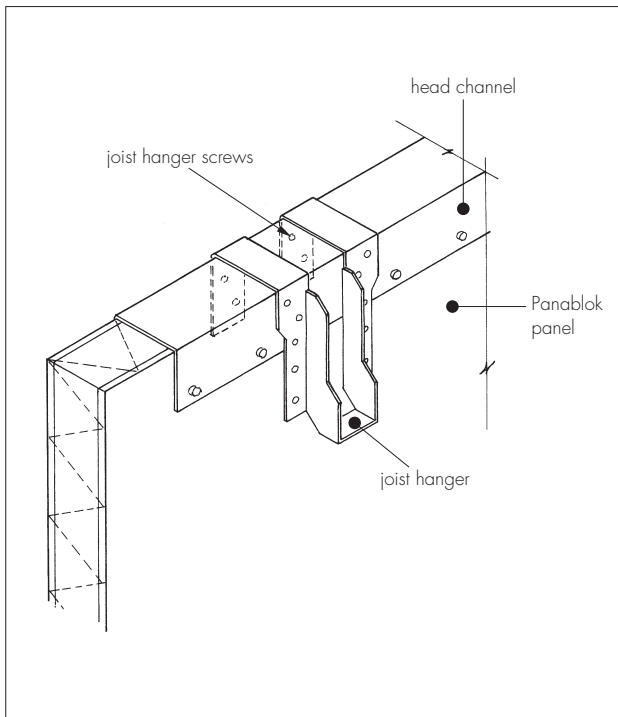

Openings

15.11 Openings should be carefully planned and the preferred method of forming the opening selected (see sections 15.12 and 15.13). Two methods for forming openings are detailed in the marketing company's installation instructions:

- Method 1: Openings are cut into the skin of the erected walling panel. A lintel must be installed over the opening.
- Method 2: Openings are formed as work proceeds by the installation of cut panel sections over and/or under the required opening. A lintel must be installed over the opening.

15.12 Where cut walling panels are used, a butt joint is necessary due to the removal of the camlocks. Joint stability is maintained by the use of metal plates, and foam applied to the joint to reinstate the insulation properties of the walling panel.

15.13 Where openings continue to floor level, the base channel may be omitted from the area of the opening as work continues or removed at a later stage. A lintel must be installed over the opening.

Fixing of windows and door frames, service battens and wall ties

15.14 Window and door frames are fixed to the external face of the panels using the brackets provided (see Figure 10).

Figure 10 Typical window detail — cavity wall leaf

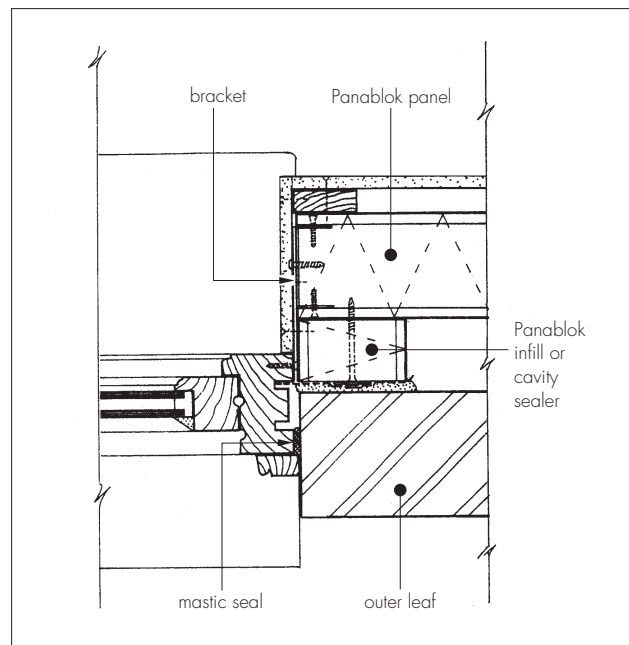

15.15 Services battens or timber grounds are fixed to the inner face of the panels at 600 mm centres using the fixings provided. A plasterboard facing is then fixed to the battens to provide a service void and a surface for internal decoration (see Figure 11).

Figure 11 Corner junction

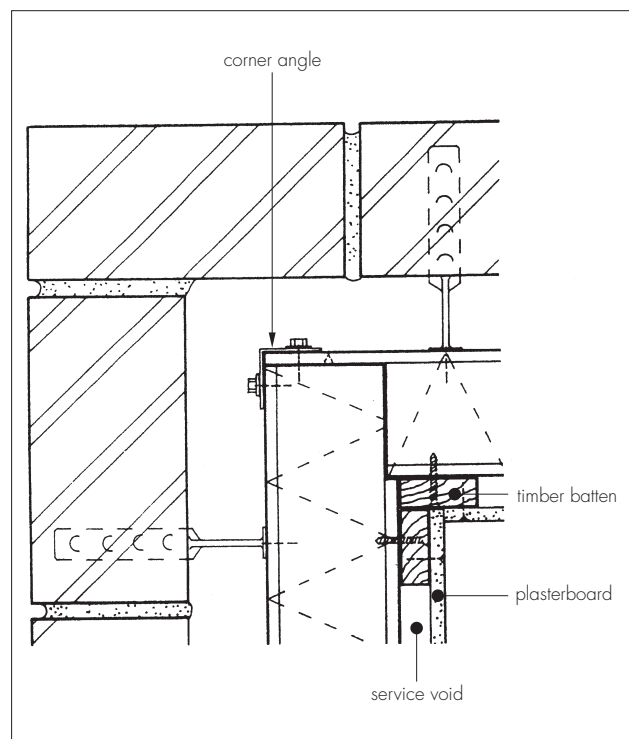

15.16 BBA approved timber-frame wall ties to receive external brick leaf must be screwed into the face of the panels, or through the face into the metal studs at the required spacing using suitable fasteners. Dovetail slot ties in accordance with BS 5628-1 : 1992 or frame cramps to BS EN 10327 : 2004 can also be used. Details of pull-out forces for fasteners can be obtained from the Certificate holder.

Technical Investigations

The following is a summary of the technical investigations carried out on the Panablok 100 Preformed Structural Walling System.

16 Investigations

An examination was made of text data relating to:

- racking tests to BS 5268-6.1 : 1996
- vertical loading tests
- fire resistance test to BS 476-21 : 1987
- sound reduction test to BS 2750-3 : 1995.

17 Other investigations

17.1 An examination was made of calculations on thermal properties, in particular U values.

17.2 Existing information relating to the durability of the system and compatibility of materials in contact was examined.

17.3 The manufacturing process was examined, including the methods adopted for quality control, and details were obtained of the quality and composition of materials.

Bibliography

BS 476-21 : 1987 *Fire tests on building materials and structures — Methods for determination of the fire resistance of loadbearing elements of construction*

BS 1230-1 : 1985 *Gypsum plasterboard — Specification for plasterboard excluding materials submitted to secondary operations*

BS 2750-3 : 1995 *Measurement of sound insulation in buildings and of building elements — Laboratory measurements of airborne sound insulation of building elements*

BS 5250 : 2002 *Code of practice for control of condensation in buildings*

BS 5268-3 : 1998 *Structural use of timber — Code of practice for trussed rafter roofs*
BS 5268-6.1 : 1996 *Structural use of timber — Code of practice for timber frame walls — Dwellings not exceeding four storeys*

BS 5628-1 : 1992 *Code of practice for use of masonry — Structural use of unreinforced masonry*

BS 5950-5 : 1998 *Structural use of steelwork in building — Code of practice for design of cold formed thin gauge sections*

BS 6093 : 1993 *Code of practice for design of joints and jointing in building construction*

BS 6150 : 1991 *Code of practice for painting of buildings*

BS 8200 : 1985 *Code of practice for design of non-loadbearing external vertical enclosures of buildings*

BS 8204-1 : 2003 *Screeds, bases and in-situ floorings — Concrete bases and cement sand levelling screeds to receive floorings — Code of practice*

BS EN 634-2 : 1997 *Cement bonded particleboards — Specification — Requirements for OPC bonded particleboards for use in dry, humid and exterior conditions*

BS EN 10326 : 2004 *Continuously hot-dip coated strip and sheet of structural steels — Technical delivery conditions*

BS EN 10327 : 2004 *Continuously hot-dip coated strip and sheet of low carbon steels for cold forming — Technical delivery conditions*

BS EN ISO 140-4 : 1998 *Acoustics — Measurement of sound insulation in buildings and of building elements — Field measurements of airborne sound insulation between rooms*

BS EN ISO 6946 : 1997 *Building components and building elements — Thermal resistance and thermal transmittance — Calculation method*



On behalf of the British Board of Agrément

Date of issue: 18th October 2004

A handwritten signature in black ink, appearing to read 'P. C. Newson'.

Chief Executive

British Board of Agrément

P O Box No 195, Bucknalls Lane
Garston, Watford, Herts WD25 9BA

Fax: 01923 665301

©2004

e-mail: mail@bba.star.co.uk
website: www.bbacerfs.co.uk



For technical or additional information, contact the Certificate holder (see front page).
For information about the Agrément Certificate, including validity and scope, tel: Hotline 01923 665400, or check the BBA website.